

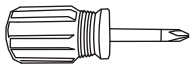

Component List

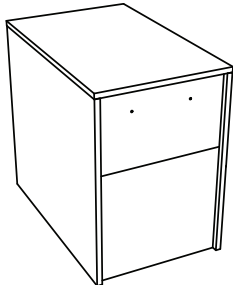

A - Phillips Screwdriver
x 1 (not provided)



B - Cabinet x 1

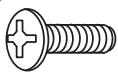

C - 5/32" x 12mm
Phillips Screw
x 20

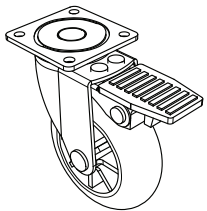

D - Brake Caster x 4

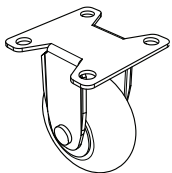

E - Center Caster x 1

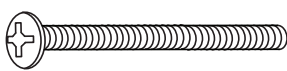

F - M4 x 37mm
Phillips Screw
x 2

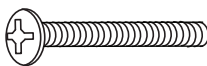

G - M4 x 25mm
Phillips Screw
x 2

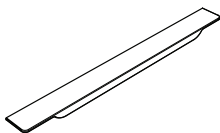

H - Pull x 2

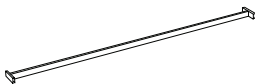

I - Letter File Bar x 2

Format is engineered for easy assembly. Carefully follow this procedure to prevent any damage.

Do not use power tools for assembly of this product.



Placement and Maintenance

Format™ Office furniture is designed for indoor use on level floors. Clean steel parts and wood veneer with a moist cloth.

Step 1

Unpack and Identify

Unpack and identify the components at left. Note that some components are shipped inside the cabinet. The assembly workspace should be a non-marring surface such as carpet. For missing hardware pieces, please contact BDI Customer Service at customerservice@bdiusa.com. For all other concerns, please contact your BDI Retailer.

Step 2

Install Casters

Carefully position **Cabinet (B)** on its back side so that bottom side is accessible, then attach a **Caster** at each of the five (5) exposed installation plates using **5/32" x 12mm Phillips Screw (C)** and a Phillips Screwdriver.

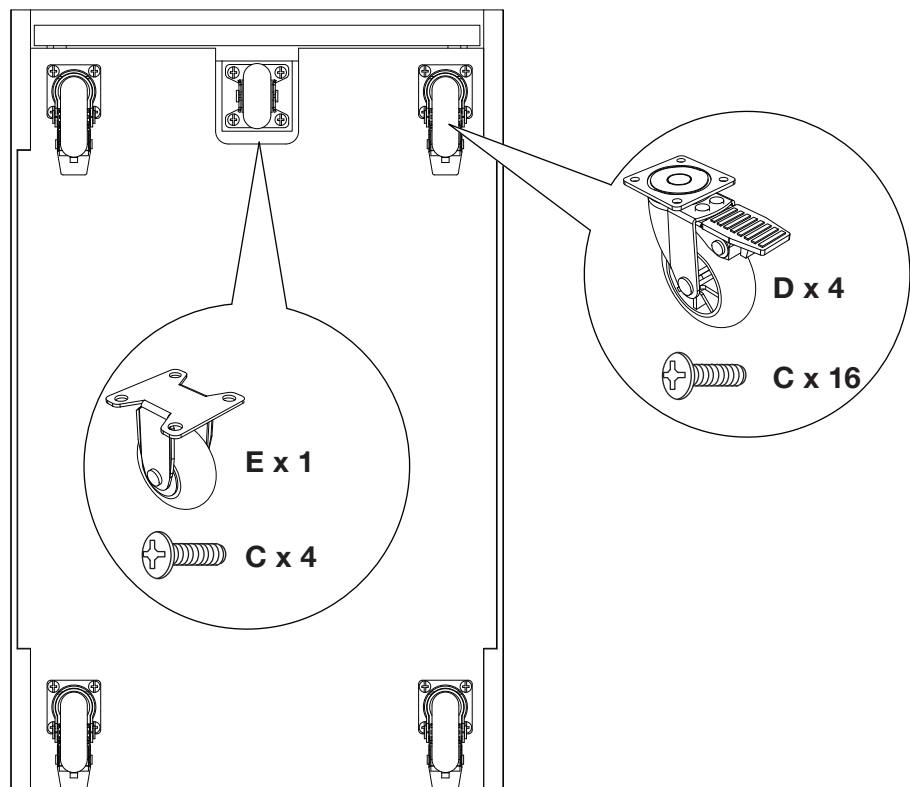

Step 3
Install Drawer Pulls.

Install Pulls.

Carefully turn pedestal upright and then install **Pull (H)** to top drawer using the **M4 x 37mm Phillips Screw (F)** and a Phillips Screwdriver. Install **Pull (H)** to bottom drawer using the **M4 x 25mm Phillips Screw (G)** and a Phillips Screwdriver.

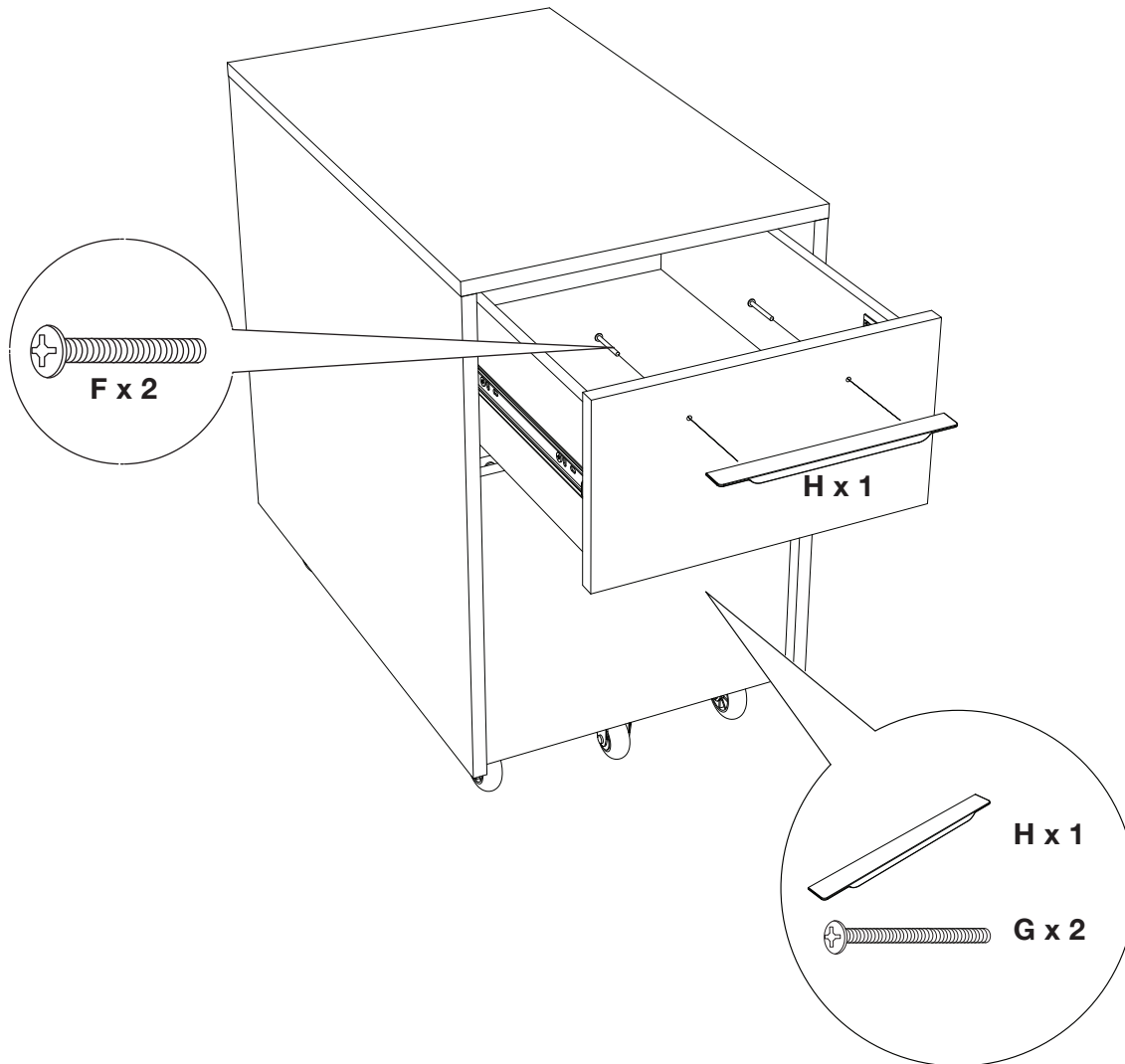

Step 4
File Folders

Users who wish to use legal-length files may install **Letter File Bars(I)** into place near front and back of file drawers.

