

www.fishman.com

FISHMAN[®]

USER GUIDE
AURA[®] SPECTRUM_{DI}

Welcome

Thank you for making Fishman a part of your acoustic experience. We are proud to offer you the finest acoustic amplification products available; high-quality professional-grade tools to empower you to sound your very best. We are confident Aura Spectrum DI will both enhance and inspire your music making.

Quick Start

Power – Install a fresh 9V battery (not included) or connect a Fishman power adaptor.

Set the controls – Volume at minimum and all other controls as shown below.

Plug in – Use standard ¼-inch and XLR shielded instrument cables.

Tune up – Step on the tuner footswitch to tune with the output muted.

Set trim – Play hard and adjust the input **trim** (on the right side) so the **clip/batt** LED flashes only occasionally.

Select an Image – Raise the **volume** and audition Images with the **select** knob. Move the **Image Bank** slider to choose the set of Images that best match the instrument you're playing. (see pages 6 thru 13)

Blend to taste – Turn left for more pickup and right for more Image.

Kill feedback – If feedback starts, change the position of the **phase** switch. For advanced feedback handling, check out the section detailing the automatic feedback filters on page 24.

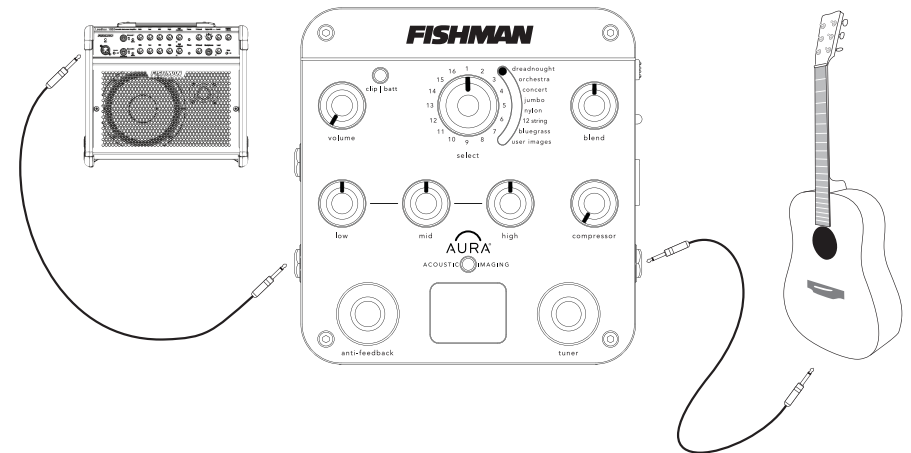

What is Aura?

Aura Acoustic Imaging Technology uses digital algorithms developed in Fishman's audio laboratories to restore a studio-miked sound to an acoustic instrument. To achieve this, we record instruments using world-class microphones and techniques to capture an "Image" of the natural sound that your acoustic instrument emits when miked in a professional studio. This Image, when recorded direct or played through an amp, mixer or PA, blends with your instrument's pickup to produce an incredibly accurate recreation of the original recording.

Aura Acoustic Imaging processors sound best when used with Fishman undersaddle pickups and magnetic soundhole pickups. When we record each instrument, we use our Acoustic Matrix undersaddle pickup. So, when you play through an Aura processor, you'll get the best results using our Acoustic Matrix pickup. We do not recommend soundboard-mounted pickups, bridge-plate pickups, multi-sensor pickups or microphones for Aura products since they include unnecessary resonances that can interfere with the Aura processing.

Choosing an Image

To get the most realistic tone from Aura Acoustic Imaging, you should always **match your Images with the instrument type** you're playing. For example, choose dreadnought Images when plugging in a dreadnought body style guitar; choose mandolin Images if you're playing a mandolin. Don't hope to derive a mandolin sound from a dreadnought or try to turn your orchestra body style guitar into a 12-string. If you are not sure which body type your guitar falls into, we suggest you audition several Images from each bank and let your ears decide. See the following pages to help match your instrument with the best Aura Image.

Aura Custom Shop

For the ultimate in Aura Imaging, be sure to check out the Aura Custom Shop at fishman.com. For a modest fee, you send us your instrument and we'll create a set of Images using our best microphones, custom recorded for you.

Aura Image Gallery

The Aura Image Gallery software manages a vast library of Images created from an ever-expanding list of instruments, and provides tools to search and store sets of Images. Browse the Image Library to find your instrument, then drag and drop an Image into an Image Set for download into Aura Spectrum.

Making Connections

Playing live

For the best sound reproduction when performing live, connect your Aura Spectrum to an acoustic instrument amp, a PA system, a powered monitor or other full-range system. The balanced XLR D.I. output eliminates an outboard D.I. and features an automatic ground lift when you use the 1/4" output, providing a high quality, noise free signal.

Going direct

For direct recording, there is no better solution than using Aura Spectrum's balanced XLR D.I. or 1/4" output. In fact, an acoustic track recorded with just a pickup can be re-recorded using Aura to restore the miked sound.

About the Image Banks

Dreadnought

Use this bank of Images with all varieties of the classic deep-body dreadnought.

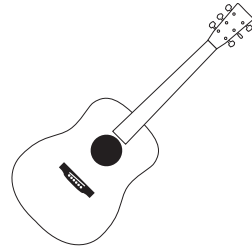

| Image # | Top Wood | Back and Sides | Microphone Type |
|---------|-----------|----------------|-----------------|
| 1 | Spruce | Rosewood | DPA® 4011 |
| 2 | Spruce | Mahogany | Soundelux® E47 |
| 3 | Spruce | Rosewood | Soundelux® E47 |
| 4 | Spruce | Rosewood | Neumann® KM84 |
| 5 | Spruce | Rosewood | Schoeps® CMC64 |
| 6 | Spruce | Rosewood | Schoeps® CMC64 |
| 7 | Spruce | Rosewood | Shure® KSM141 |
| 8 | Spruce | Rosewood | Neumann® M147 |
| 9 | Spruce | Rosewood | Neumann® M147 |
| 10 | Spruce | Rosewood | Schoeps® CMC64 |
| 11 | Spruce | Mahogany | AKG® C414 |
| 12 | Spruce | Rosewood | Neumann® U87 |
| 13 | Spruce | Rosewood | Neumann® U87 |
| 14 | Composite | Composite | DPA® 4011 |
| 15 | Spruce | Rosewood | Neumann® M147 |
| 16 | Spruce | Mahogany | Shure® SM57 |

Fishman Transducers, Inc. is not affiliated with any of the forementioned companies or their respective trademarks, registered trademarks, product models or copyrights.

Jumbo

Use these Images with large, deep-body instruments with slim waists and wide lower bouts (usually over 16").

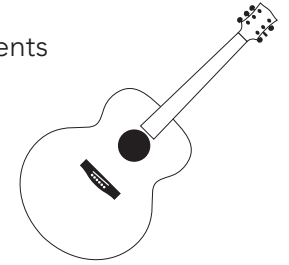

| Image # | Top Wood | Back and Sides | Microphone Type |
|---------|----------|----------------|-----------------|
| 1 | Cedar | Rosewood | Shure® SM57 |
| 2 | Spruce | Maple | AKG® C414 |
| 3 | Spruce | Maple | DPA® 4011 |
| 4 | Spruce | Maple | Schoeps® CMC64 |
| 5 | Spruce | Maple | Schoeps® CMC64 |
| 6 | Spruce | Rosewood | DPA® 4011 |
| 7 | Spruce | Rosewood | Neumann® U87 |
| 8 | Spruce | Rosewood | Shure® SM57 |
| 9 | Cedar | Rosewood | DPA® 4011 |
| 10 | Spruce | Maple | Soundelux® E47 |
| 11 | Spruce | Rosewood | Neumann® U87 |
| 12 | Spruce | Rosewood | Neumann® KM84 |
| 13 | Spruce | Maple | Shure® SM57 |
| 14 | Cedar | Rosewood | Neumann® U87 |
| 15 | Spruce | Maple | Neumann® U87 |
| 16 | Spruce | Koa | Schoeps® CMC64 |

Fishman Transducers, Inc. is not affiliated with any of the forementioned companies or their respective trademarks, registered trademarks, product models or copyrights.

About the Image Banks (continued)

Concert

Use the Concert Images with small-body, short-scale instruments with thin waists, like 0, 00 and L-00 styles; typically finger-picking guitars as well as parlor and travel instruments.

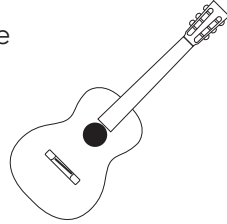

| Image # | Top Wood | Back and Sides | Microphone Type |
|---------|----------|----------------|-----------------|
| 1 | Spruce | Rosewood | Schoeps® CMC64 |
| 2 | Spruce | Rosewood | Schoeps® CMC64 |
| 3 | Spruce | Maple | Neumann® M147 |
| 4 | Spruce | Rosewood | Shure® SM57 |
| 5 | Mahogany | Mahogany | DPA® 4011 |
| 6 | Spruce | Rosewood | Neumann® M147 |
| 7 | Spruce | Koa | Neumann® U87 |
| 8 | Spruce | Rosewood | DPA® 4011 |
| 9 | Mahogany | Mahogany | Neumann® M147 |
| 10 | Mahogany | Mahogany | Soundelux® E47 |
| 11 | Mahogany | Mahogany | DPA® 4011 |
| 12 | Spruce | Maple | Schoeps® CMC64 |
| 13 | Spruce | Rosewood | Neumann® M147 |
| 14 | Spruce | Rosewood | Neumann® M147 |
| 15 | Spruce | Rosewood | Schoeps® CMC64 |
| 16 | Spruce | Koa | Schoeps® CMC64 |

Fishman Transducers, Inc. is not affiliated with any of the forementioned companies or their respective trademarks, registered trademarks, product models or copyrights.

Orchestra

For guitars larger than concert but smaller than dreadnought, the Orchestra Images work well with OM & 000 styles as well as auditorium and other narrow-waist mid-size, medium-depth instruments.



| Image # | Top Wood | Back and Sides | Microphone Type |
|---------|----------|----------------|------------------|
| 1 | Spruce | Rosewood | Soundelux® E47 |
| 2 | Spruce | Rosewood | Neumann® M147 |
| 3 | Spruce | Mahogany | Schoeps® CMC64 |
| 4 | Spruce | Mahogany | Neumann® M147 |
| 5 | Spruce | Mahogany | Soundelux® E47 |
| 6 | Spruce | Rosewood | Neumann® KM84 |
| 7 | Spruce | Mahogany | Soundelux® E47 |
| 8 | Spruce | Rosewood | Soundelux® E47 |
| 9 | Spruce | Mahogany | DPA® 4011 |
| 10 | Spruce | Rosewood | Soundelux® E47 |
| 11 | Spruce | Rosewood | Shure® Beta 58A® |
| 12 | Spruce | Rosewood | Schoeps® CMC64 |
| 13 | Spruce | Mahogany | Neumann® M147 |
| 14 | Spruce | Rosewood | Neumann® KM84 |
| 15 | Spruce | Rosewood | Schoeps® CMC64 |
| 16 | Spruce | Rosewood | Schoeps® CMC64 |

Fishman Transducers, Inc. is not affiliated with any of the forementioned companies or their respective trademarks, registered trademarks, product models or copyrights.

About the Image Banks (continued)

Nylon

Use with all medium-depth classical and thin-body acoustic-electric nylon-string guitars.

Note: Use only an undersaddle pickup with the Nylon pedal.

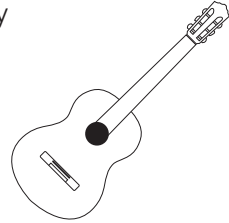

| Image # | Top Wood | Back and Sides | Microphone Type |
|---------|----------|----------------|-----------------|
| 1 | Cedar | Rosewood | Schoeps® CMC64 |
| 2 | Spruce | Cypress | Soundelux® E47 |
| 3 | Spruce | Rosewood | Soundelux® E47 |
| 4 | Cedar | Rosewood | Neumann® M147 |
| 5 | Spruce | Rosewood | DPA® 4011 |
| 6 | Spruce | Cypress | AKG® C1000S |
| 7 | Spruce | Rosewood | Soundelux® E47 |
| 8 | Spruce | Mahogany | Neumann® M147 |
| 9 | Cedar | Rosewood | Soundelux® E47 |
| 10 | Spruce | Rosewood | Neumann® M147 |
| 11 | Cedar | Rosewood | AKG® C414 |
| 12 | Cedar | Rosewood | DPA® 4011 |
| 13 | Cedar | Rosewood | Shure® KSM141 |
| 14 | Spruce | Cypress | DPA® 4011 |
| 15 | Cedar | Rosewood | Neumann® M147 |
| 16 | Spruce | Cypress | Neumann® M147 |

Fishman Transducers, Inc. is not affiliated with any of the forementioned companies or their respective trademarks, registered trademarks, product models or copyrights.

12 String

These are typically jumbo or dreadnought size instruments. The heavier bracing for 12 string guitars creates a unique sound and has its own Aura Image bank

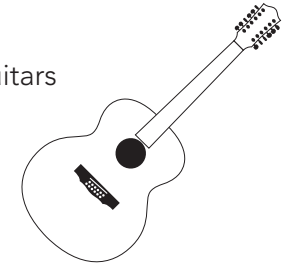

| Image # | Top Wood | Back and Sides | Microphone Type |
|---------|----------|----------------|-----------------|
| 1 | Spruce | Rosewood | Soundelux® E47 |
| 2 | Spruce | Maple | AKG® C414 |
| 3 | Spruce | Rosewood | Soundelux® E47 |
| 4 | Spruce | Rosewood | Neumann® KM84 |
| 5 | Spruce | Rosewood | Soundelux® E47 |
| 6 | Spruce | Rosewood | DPA® 4011 |
| 7 | Spruce | Rosewood | Shure® KSM141 |
| 8 | Spruce | Rosewood | Neumann® M147 |
| 9 | Mahogany | Mahogany | Schoeps® CMC64 |
| 10 | Spruce | Rosewood | Schoeps® CMC64 |
| 11 | Spruce | Mahogany | Shure® SM57 |
| 12 | Spruce | Mahogany | Neumann® U87 |
| 13 | Spruce | Rosewood | Neumann® U87 |
| 14 | Spruce | Maple | Soundelux® E47 |
| 15 | Spruce | Rosewood | Shure® SM57 |
| 16 | Spruce | Koa | Schoeps® CMC64 |

Fishman Transducers, Inc. is not affiliated with any of the forementioned companies or their respective trademarks, registered trademarks, product models or copyrights.

About the Image Banks (continued)

Bluegrass

This bank offers a sampling of fiddle, mandolin, and resophonic Images.

| Image # | Instrument | Back and Sides | Microphone Type |
|---------|------------|----------------|----------------------|
| 1 | Fiddle | Maple | Neumann® U87 |
| 2 | Fiddle | Maple | Soundelux® E47 |
| 3 | Fiddle | Maple | RCA® Ribbon |
| 4 | Fiddle | Maple | Royer® R-121 |
| 5 | Fiddle | Maple | Neumann® KM54 |
| 6 | Mandolin | Maple | Neumann® U87 |
| 7 | Mandolin | Maple | Neumann® KM84 |
| 8 | Mandolin | Maple | Neumann® U87 |
| 9 | Mandolin | Maple | Neumann® M147 |
| 10 | Mandolin | Maple | DPA® 4011 |
| 11 | Resophonic | Finland Birch | Schoeps® CMC64 |
| 12 | Resophonic | Finland Birch | Shure® SM57 |
| 13 | Resophonic | Finland Birch | Neumann® KM84 |
| 14 | Resophonic | Finland Birch | Neumann® U87 |
| 15 | Resophonic | Finland Birch | Neumann® M147 |
| 16 | Resophonic | Finland Birch | Groove Tubes® Velo8® |

Fishman Transducers, Inc. is not affiliated with any of the forementioned companies or their respective trademarks, registered trademarks, product models or copyrights.

User Images

This bank ships with a diverse variety of guitars randomly selected from our Aura Image Gallery. You can overwrite any of the 16 locations with Images you download from the Aura Image Gallery software. See page 26 for more details on downloading Images.

| Image # | Top Wood | Back and Sides | Microphone Type |
|---------|-----------|----------------|-----------------|
| 1 | Spruce | Rosewood | Shure® SM57 |
| 2 | Spruce | Rosewood | Schoeps® CMC64 |
| 3 | Composite | Composite | Soundelux® E47 |
| 4 | Spruce | Mahogany | Neumann® KM84 |
| 5 | Spruce | Rosewood | Soundelux® E47 |
| 6 | Spruce | Mahogany | DPA® 4011 |
| 7 | Spruce | Rosewood | Neumann® U87 |
| 8 | Spruce | Rosewood | Soundelux® E47 |
| 9 | Spruce | Rosewood | Schoeps® CMC64 |
| 10 | Spruce | Rosewood | Neumann® U87 |
| 11 | Spruce | Rosewood | Neumann® M147 |
| 12 | Spruce | Rosewood | DPA® 4011 |
| 13 | Mahogany | Mahogany | Neumann® U87 |
| 14 | Spruce | Rosewood | Neumann® M147 |
| 15 | Spruce | Rosewood | AKG® C414 |
| 16 | Spruce | Sapele | Schoeps® CMC64 |

Fishman Transducers, Inc. is not affiliated with any of the forementioned companies or their respective trademarks, registered trademarks, product models or copyrights.

Left Side Panel

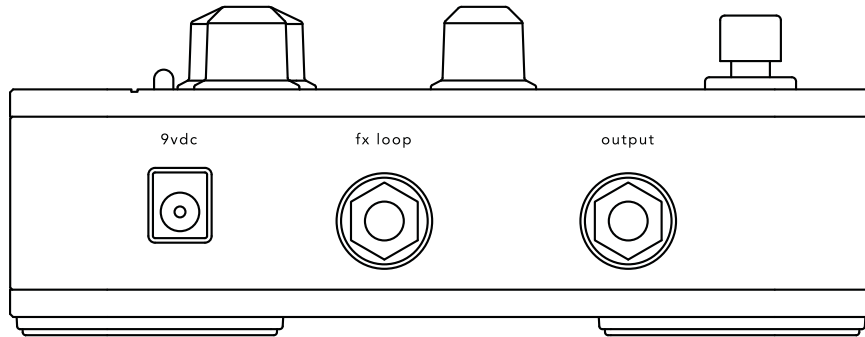

Output

Use a standard ¼-inch instrument cable to connect the **output** to your amplifier, mixer or effects devices. You can also connect this **output** to an unbalanced input on a recording system.

Connecting a guitar cable here will also lift the ground on the XLR D.I. output, preventing unwanted ground loops.

FX Loop

This tip/ring/sleeve connection allows you to insert external devices, such as the Fishman AFX Acoustic Effects, between Aura Spectrum's blended signal and the main outputs. Any pedals you connect here will appear at the 1/4" and XLR D.I. outputs. The overall output level will still be affected by Aura Spectrum's **volume** control.

9VDC

Power may be supplied by either a 9V battery (battery compartment underneath the pedal) or the Fishman 910-R (for 110V).

Right Side Panel

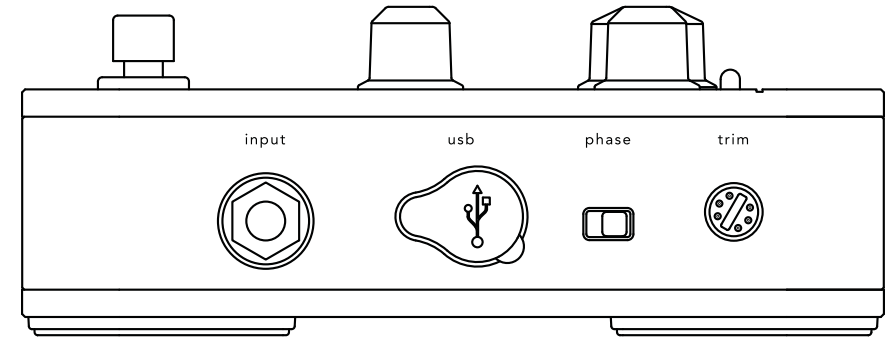

Trim

Raise or lower the **trim** to optimize the input level for your pickup. Play hard and adjust **trim** so **clip/batt** flashes occasionally. Some pickup systems may not cause the light to flash at all and other onboard preamps may require you to turn their output down to achieve an optimum level.

Phase

Use the **phase** switch to improve bass response at low volume and suppress feedback at high volume. Move the **phase** switch and leave it in the position most pleasing to your ear.

USB

After installing Aura Image Gallery software, connect your computer here.

Input

Plug in your guitar here with a standard ¼-inch instrument cable. If you have a passive undersaddle pickup (no battery onboard), always plug into the Aura Imaging Pedal first, even if you use a pedal tuner.

Insert a plug into the **input** jack, and the Aura Imaging Pedal powers up. To conserve the battery, remove the plug from the **input** when not in use.

Top Side Panel

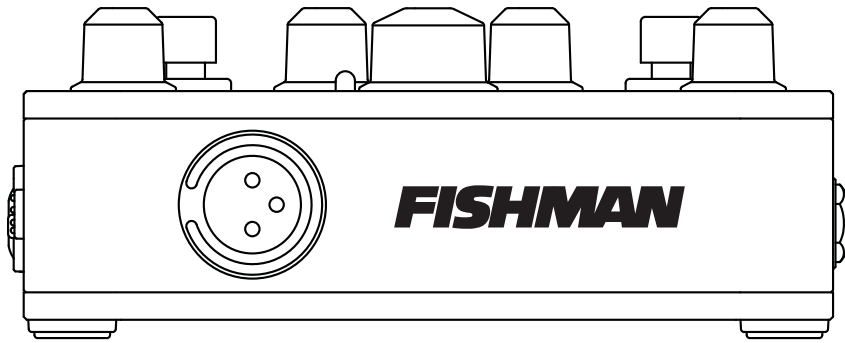

XLR D.I. Output

Connect a standard microphone cable here to feed recording equipment or a sound reinforcement mixing console. When the 1/4" output is also connected, this D.I. output's ground is automatically lifted to prevent any unwanted ground loops.

Front Panel Controls

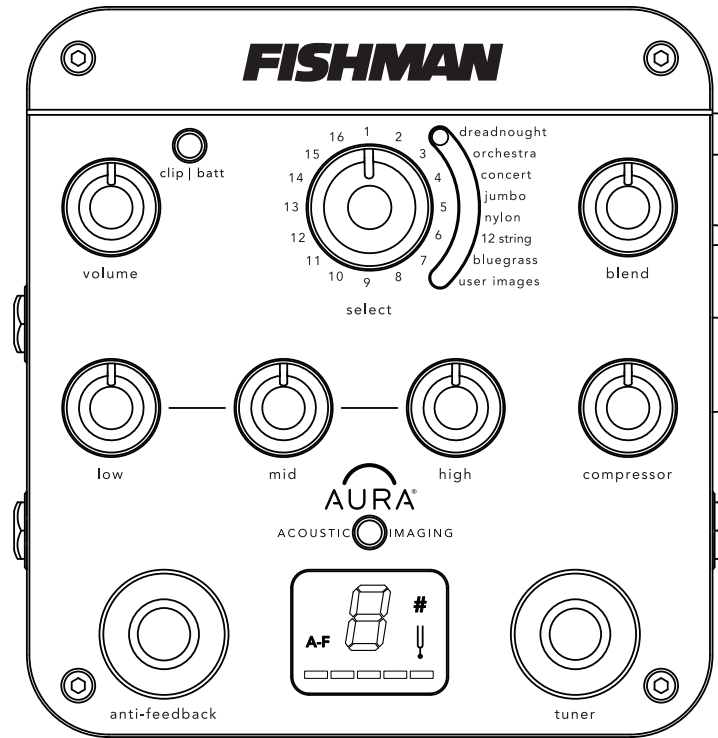

Volume

The **volume** control affects the overall output level coming from both the 1/4" and the XLR D.I outputs. For the cleanest signal, set the **volume** as high as possible without clipping the next device in the signal chain. If you hear distortion and the **clip/batt** light is not flashing, reduce the **volume**.

Select

The **select** knob allows you to choose among the 16 Images available for each of the eight different Image Banks. Move the **select** slider to choose a bank of Images that best match the style of instrument you're playing, then select through the 16 Images to find the ones that sound best. Try all 16 within each bank and adjust the **blend** knob to obtain more or less character.

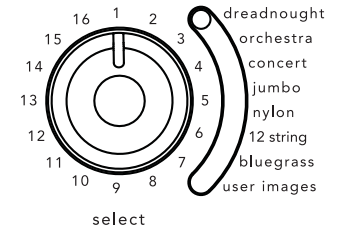

Blend

Position the **blend** knob straight-up at 12 o'clock and you'll hear a 50/50 mix of Image and pickup. Turn the **blend** all the way right for just Image; all the way left for just pickup. Most performers blend in some pickup with the Image for clarity and definition.

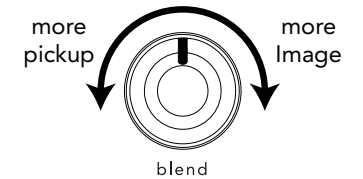

Suggestions

- For live performance try backing off the Image by setting **blend** to about 10 or 11 o'clock or about 65% pickup. You won't need too much Image blended in to achieve a great live sound. If feedback occurs, flip the **phase** switch.
- For recording, try blending in more Image for a realistic acoustic sound. Set the **blend** to taste. Again, you'll often get good results with a little bit of pickup blended in with the Image for clarity and definition.

Front Panel Controls (cont'd)

Pickup EQ: Low, Mid, High

As a default, the **low**, **mid**, and **high** tone controls affect the sound of the **pickup signal only**, allowing you to further refine the sound of your instrument without excessive alterations to the chosen Image.

A Global EQ mode may also be selected, applying the same EQ settings to both the pickup and Image path simultaneously.

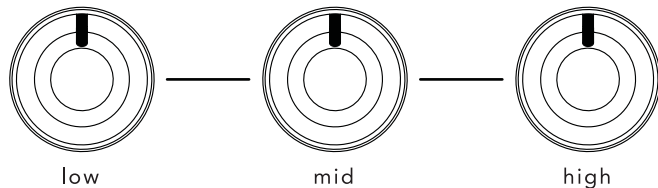

Compressor

The **compressor** control adjusts several settings within a sophisticated automatic leveling circuit.

As you turn this knob clockwise, your overall playing dynamics become increasingly limited, making softer notes louder and controlling loud spikes in your playing. This can be helpful in performances where you desire a more even level to your playing. At its maximum setting, there may be some overall increase in the output level.

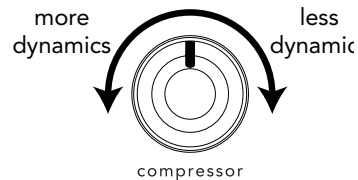

Global vs. Pickup EQ

When shipped from our factory, the **low**, **mid**, and **high** tone controls are set to affect the sound of the **pickup signal only**. This is referred to as Pickup EQ mode. However, a Global EQ mode may also be selected which applies the same EQ settings to both the pickup and Image signals simultaneously (or "globally").

When you power on Aura Spectrum, watch the tuner display for a "P" or a "G" indicating the currently selected mode.

To select Global EQ mode:

1. Hold the **tuner** button while Powering on.
2. The display flashes a "P" indicating that the unit is currently in Pickup EQ mode.
3. Press the **anti-feedback** button once and the display now flashes a "G" indicating Global EQ mode is now selected.
4. Press the **tuner** button to select Global EQ and resume powering on to normal playing mode.

To return to Pickup EQ mode:

1. Hold the **tuner** button while Powering on.
2. The display flashes a "G" indicating that the unit is currently in Global EQ mode.
3. Press the **anti-feedback** button once and the display now flashes a "P" indicating Pickup EQ mode is now selected.
4. Press **tuner** button to select Pickup EQ and resume powering on to normal playing mode.

Front Panel Controls (cont'd)

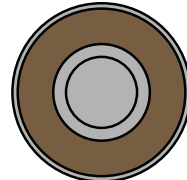
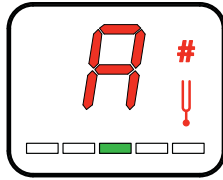

tuner

Tuner Footswitch

Step on the **tuner** footswitch to enable the digital chromatic tuner. You'll know it's active when the white Aura LED goes dark and the tuning fork in the center display is lit red. As a default, Aura Spectrum's output is muted allowing you to tune silently.

To tune, play a note lightly and watch the display. The note name will be indicated as a single letter and a small # sign will be lit whenever the displayed note is raised one half step. The note being sharp, flat, or in-tune will be displayed using the five multi-colored LEDs in the tuner window and below the tuning note. When there is no audio input, or you're not playing, a "-" will appear in the display.

This digital chromatic tuner accommodates all standard and alternate tunings and is calibrated to A = 440.

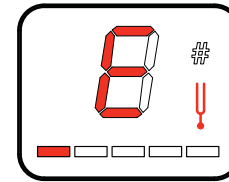

an 'E' played very flat

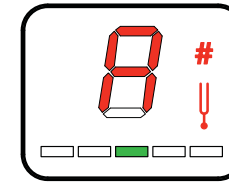

an 'A#' played in-tune

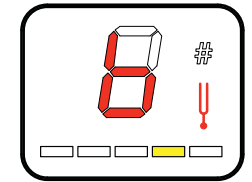

a 'B' played slightly sharp

Tuner Option

When shipped from the factory, the audio output is muted when the tuner is engaged.

Alternately, you have the option to use the tuner without muting your output. To choose this option, hold the footswitch down until the Aura LED flashes. Repeat to return to the factory state.

Bypass mode

Aura Spectrum allows you completely bypass the Image, EQ, and Compressor processing. To enter bypass mode, press both the **anti-feedback** and **tuner** switches together. The white Aura LED will alternate slowly with the tuner LED to indicate bypass mode is active. To exit bypass mode, press both foot switches again.

With bypass active, all controls including the tuner are functional, however you will not hear any of the changes until you exit bypass.

Front Panel Controls (cont'd)

Anti-Feedback Footswitch

Use this search-and-destroy anti-feedback filter in addition to the **phase** switch to control feedback during a performance. Aura Spectrum's automatic anti-feedback filter can apply up to three separate notch filters, which are essentially very precise tone controls that reduce only a small piece of the audio band. When activated, the filter determines where the offending resonances are and only reduces the frequencies on which they are centered.

While the **anti-feedback** control is very effective, it's best if you spend some time while setting up before a performance and catch any issues before you begin to play. With some practice, you'll find you can also use it to "fix" any resonant notes that may stand out in a particular venue.

Using the automatic **anti-feedback** control:

1. Press and hold **anti-feedback** footswitch for 2 seconds. The tuner display will flash a "1" to indicate it is searching for the first feedback.
2. Turn up your **volume**, then either dampen the strings while tapping the body or play the troublesome note until the feedback begins. The filter will automatically identify and eliminate the feedback. The "1" in the display will light solid as will the "A-F" indicator.
3. At this point, you may continue to turn up your **volume** as in step 2 to catch up to two more problematic resonances. Each is indicated via a flashing "2" or "3" during the search, turning to solid lit numerals when the resonance has been identified.
4. You may tap the **anti-feedback** footswitch at any time to cancel the search. The circuit will hold the offending frequenc(ies) in memory until you repeat the process again.

You may also turn the filter on or off at any time by tapping the footswitch. When enabled, the "A-F" lights to indicate the filters are active and the number of filters being applied will be briefly displayed.

About Phase and Anti-Feedback

There are two features provided to help control acoustic feedback, the **phase** switch and the **anti-feedback** control.

Feedback usually occurs in the lowest octaves of your instrument. The natural resonances which produce an instrument's tone also react with amplified sound. The louder an instrument is amplified, the more it will interact. Feedback occurs when a note on the instrument resonates in sync with the amplified sound, reinforcing and building to a sustained howl.

The **phase** switch flips the polarity of your instrument signal from positive to negative, changing its relationship to the sound coming from the amplifier. One phase setting usually provides better resistance to feedback than the other and will vary depending on the instrument and playing environment. Another approach to determining optimal phase is the selection which sounds or feels most natural when playing.

The **phase** switch also affects the signal polarity to the balanced XLR D.I. and 1/4 inch outputs, synchronizing the amplifier with other sound systems in use.

In certain playing environments the **phase** switch may not have an audible impact.

The **anti-feedback** control is an automatic variable frequency notch filter designed to subdue a resonant peak on the instrument which is prone to feedback. Check out page 24 for more exact details of its operation.

Downloading Images

The Aura Image Gallery software manages a vast library of Images created from an ever-expanding list of instruments, and provides tools to search and store sets of Images.

If you can't find your exact instrument in the list, use the built-in Image Wizard to find the closest match. For example, if one of our hundreds of Images doesn't match your instrument exactly, you can still find a great sounding Image by matching similar tone woods and body styles. Experiment with these tools, and use your ears to determine what sounds best for your playing or musical style.

To access this library of additional instrument Images, install the Aura Image Gallery on your computer. Then, gently remove the USB cover from the right side of the unit and connect the included USB cable to the side of the preamp and your computer. Create a new Image Set and load your Images into Aura Spectrum

Be sure to install the Aura Image Gallery software prior to connecting Aura Spectrum for the first time.

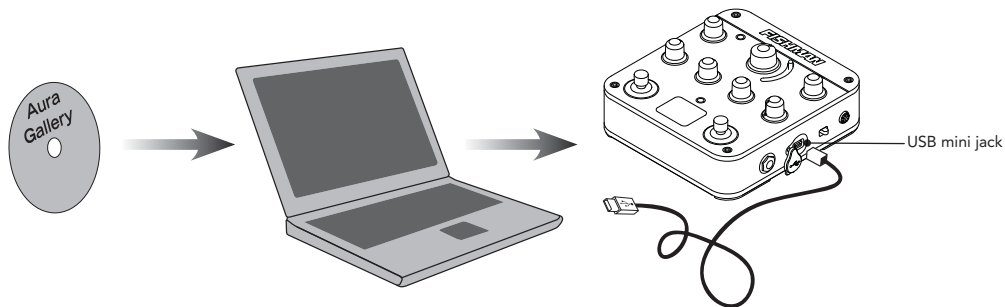

Battery Replacement

The **clip/batt** indicator will light steadily when it is time to change the battery. Open the battery door underneath the pedal and install a fresh 9V alkaline or lithium battery. When the **clip/batt** LED comes on you have approximately one hour of remaining battery life.

Signal Flow

The illustration below shows the audio signal as it flows through Aura Spectrum. Note: When Global EQ mode is selected, the tone controls also affect the Image signal as indicated by * (see pages 20 & 21).

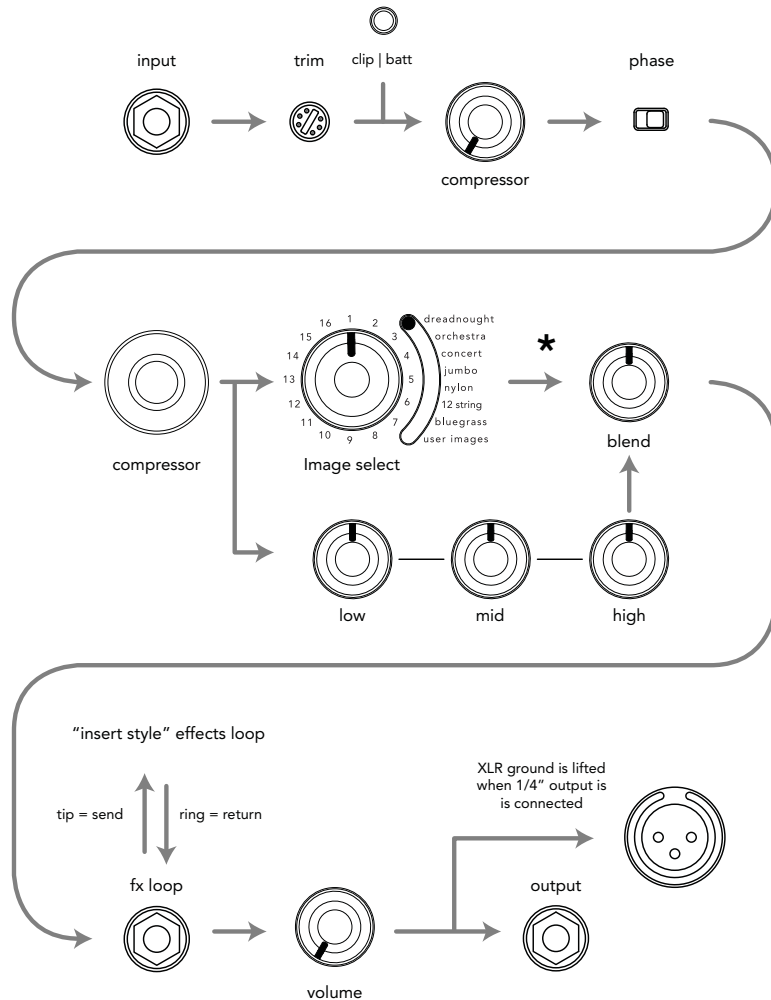

Specifications

| | |
|---|--|
| Input impedance: | 10M Ohm |
| Input trim gain range: | -10dB to +2dB |
| Nominal Output impedance: | 3.5k Ohm |
| Maximum Output level (onset of clipping): | +3dBV |
| Digital signal path: | |
| A/D, D/A conversion: | 24-bit |
| Signal processing: | 32-bit |
| Baseline noise: | -97dBV (A-weighted) |
| Dynamic range: | 100dB (A-weighted) |
| Power supply: | 9V battery or 9VDC adapter |
| Typical in-use current consumption: | 25mA |
| Typical 9V battery life: | 20 hours using alkaline battery 40 hours using lithium battery) |
| 9V adapter: | Fishman 910-R (for 110V) or suitable filtered and regulated, 200mA type, tip = negative |
| Tone Controls: | |
| Low (bass) control: | ±12dB @ 70Hz |
| Midrange control: | ±12dB @ 1kHz |
| High (treble) control: | ±12dB @ 6.5kHz |
| Anti-Feedback Notch Filter (3 notches): | 100Hz Default Frequency 50Hz to 750Hz Search Range 0.25 Octave bandwidth 13.5dB Attenuation |
| Phase switch: | Forward position = non-inverting |
| All specifications subject to change without notice | |

FISHMAN
www.fishman.com