

MUXLICER

USER MANUAL



POWERING THE MODULE | THANKS FOR PURCHASING A MODULE FROM BEFACO!
 MODULE BEFORE YOU PLUG THIS MODULE IN...

1. **Disconnect your cabinet from the mains.**
2. **Triple check the power cord polarity.** The coloured line on the cable (pin number one) is the -12V rail.
3. If you plug the module backwards you might burn it out and unfortunately this is not covered by the warranty.
4. If you have any questions about this product feel free to contact us: befacosynth@gmail.com

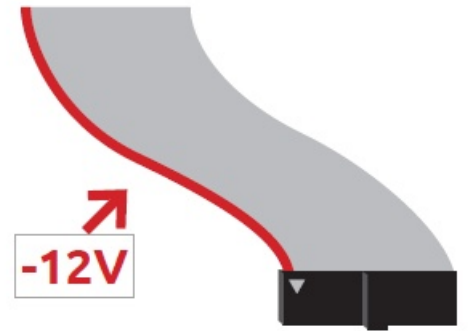

INTRODUCTION | WHAT IS MUXLICER?

Muxlicer is an eight channel, CV adresable bidirectional analog switch and gate generator. It is designed with a high "function per HP ratio" philosophy, to have maximum flexibility in minimum space. It is divided in three main blocks:

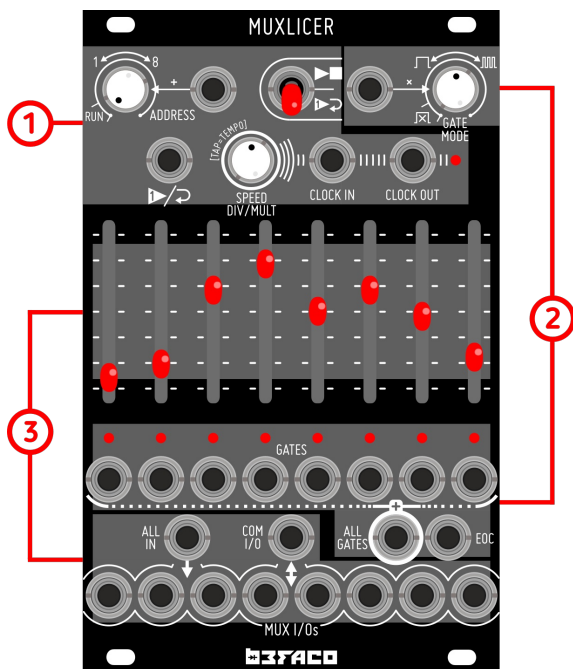

1. **Digital Step Controller**
 Featuring Tap Tempo, Voltage controlled address and two on board clock dividers/multipliers (one for Clock IN and one for Clock Out).
2. **Gate Generator**
 With independent Mix and EOC outputs, voltage controlled repetition and behaviour.
3. **Analog Switch (a.k.a Mux/DeMux)**
 Each I/O can pass analog or digital signals in either direction.

WITH THIS THINGY INSTALLED IN YOUR RACK YOU CAN:

- * Route any modular audio or CV signal from one IN up to eight OUTs or viceversa.
- * Generate CV and Gate signals, been able to work as Sequencer.
- * Cut audio signals in rhythmical slices with independent volume.
- * Chop different audio signals in a rhythmical way.
- * Generate complex CV/Gate patterns from any audio or CV moving signal.

FUNCTIONAL
BLOCKS

DIGITAL STEP CONTROLLER



ADDRESS KNOB/CV IN

Address CV IN and its associated manual control "Address Knob" sets the active step either via voltage or manually. At 0v or Run position, the module plays the entire sequence from step 1 to 8 but when they are in other value than 0 Muxlicer will jump to a step relative to the sum of both parameters.

It works on a synchronous way, so it only will works during playback, and will always wait for the next clock pulse to react.

With the Address knob top anticlockwise, CV ranges goes from 0 to 10v. With the pot at the middle CVs go from -5v to 5v, and with the knob top clockwise -10v to 0v will be accepted. Other voltages are just ignored and don't represent any danger for the module.

The address knob move the count from 1 to 8 (clockwise). The address CV moves each step in an equally voltage/step relation. Voltages above the maximum are just ignored.

5v CV in is also possible changing the CV range switch (The small switch from the back of the module).

You can use this Input to create random sequences or unives ways of counting. Just send any complex CV signal to Address IN and watch the sequence. During playback Muxlicer always rising edge so you can try any signal (even audio rates) because you will be allways on sync.

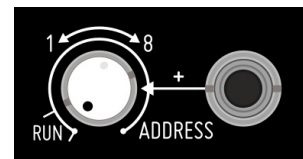

PLAY SWITCH

Play Switch is momentary and have two positions (up click and down click):

Down click. Have dual function. It Works as **"Manual Reset"** during playback and as **"One Shot Play"** during stop. Manual reset will return the count to the step 1 regardless of any other parameter. One shot play will start the count, and stop always at step 8. A down click before One Shot play will reset the count to the step one.

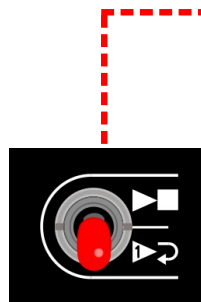

Up Click. Works as **"Start/Stop"**. One click and Muxlicer will start the count from left to right, beginning always from the step 1. With a second up click, it stops at the current position. (During playback or One Shot play)

RESET/ONE SHOT IN

This input has dual function (exactly same functions as Play switch Down click). It Works as **“Reset IN”** during play and as **“One shot play IN”** during stop.



During play: When a trigger or gate is present the count will be reset to the step 1, independently of any other parameters. Connect Gate outs to this input limit the amount of steps that Muxlicer counts.

During stop: This input will start a “One Shot” cycle. Muxlicer will count until 8 then stop. Use this to generate gated arpeggios or (together with the EOC Out) chain more than one muxlicer in series. If a second trigger is received before the count finished, it will reset to step one.

SPEED DIV/MULT ENCODER

This encoder have four different functions:

1. Tap Tempo

Tap this button twice the tempo will be set at the speed of the interval between this two taps. If you tap more than twice (in a short time) the time between them will be averaged to improve timing precision. Tempo adjustments are stored in nonvolatile memory so it remains even when the device is turned off.

2. Count Speed

Turning the encoder will always change the speed. When the module works with internal clock it change the tempo. When the module works with External clock it divides or multiplies the incoming clock.

3. Clock Out Div/Mult

Holding the encoder down and turning it the same time you can divide or multiply the Clock Output.

4. CV Range

Holding the encoder down and pressing the Play Switch Up or down at the same time (without releasing the encoder), you can adjust the range of the CV at Com I/O. Long push of Play switch, will move fast, and short push will move on small increments. All Speed adjustments are stored in nonvolatile memory.

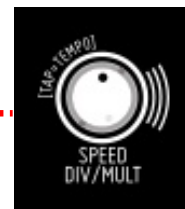

FUNCTIONAL
BLOCKS

DIGITAL STEP CONTROLLER

CLOCK IN

Synchronize Muxlicer with an incoming clock signal. Each rising edge, it will advance an amount of steps that depend on the "Div/Mult" setting. Muxlicer automatically detects when something is plugged to this IN switching from Internal to external clock. Every time that a cable is plugged to its Input, Muxlicer resets the "Div/Mult" setting to 1/1.

CLOCK OUT

Outputs the clock (either internal or external) divided or multiplied by an entire number. By default it initializes after Play or Play One shot, and stops when Muxlicer stops counting. If you want the opposite behaviour so it always keep running even if you stop the module, **hold the Play switch up for three second while the module stopped** (you will see the Clock led frozen for one second). Turning On the module while pressing down the Play Switch removes all the steps from **Clock Out** that are not **Quadratic**.

FUNCTIONAL
BLOCKS

GATE GENERATOR

GATE MODE

This knob and its associated IN, controls Gates behaviour. Moving the knob clockwise (or adding CV at the CV IN) gates will change behaviour on the next sequence:

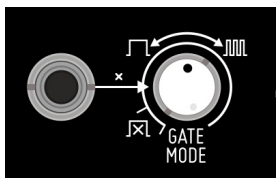

1. No Gate
2. Gate = Step Time
3. Half Step Time
4. Two Gates per Step
5. Three Gates per Step
6. Four Gates per Step
7. Five Gates per Step
8. Six Gates per Step
9. Seven Gates per Step
10. Eight Gates per Step

Turning On the module while pressing up the Play Switch removes all the steps from **Gate Mode** that are not **Quadratic (1, 3, 5, 6, 7)**

To come back to normal Gate behaviour just repeat the procedure.

Gate Mode IN, is normalized to 10v so the knob acts as a manual control when no CV is present. When CV is present the Knob acts as an attenuator. 10v CV are accepted, but most usable range is from 0 to 5v. Other voltages are ignored.

GATE OUTS

Output gates each time the associated step is activated depending on the Gate Mode Knob and the corresponding CV.

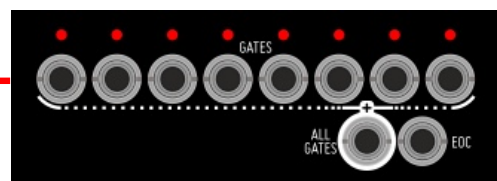

GATE LEDS

This LEDs blink always when a Gate is active. They indicate also which step is active at this time.

ALL GATES OUT

Outputs a digital sum of all the gates (logical OR)

EOC (End of Cycle) OUT

Outputs a short trigger when the count reach the end of the step 8. **It works only during play and not if step eight is reached with Address IN.** Is useful for chaining more than one Muxlicer in series or to trigger any other event like envelopes.

FUNCTIONAL BLOCKS | ANALOG SWITCH



WHAT IS AN ANALOG SWITCH?

An analog switch is a switching device capable of switching or routing analog signals. In the case of Muxlicer the switch is reversible, this means that you can send 8 different signals to 1 destination or in the opposite way, send 1 signal to 8 different destinations.

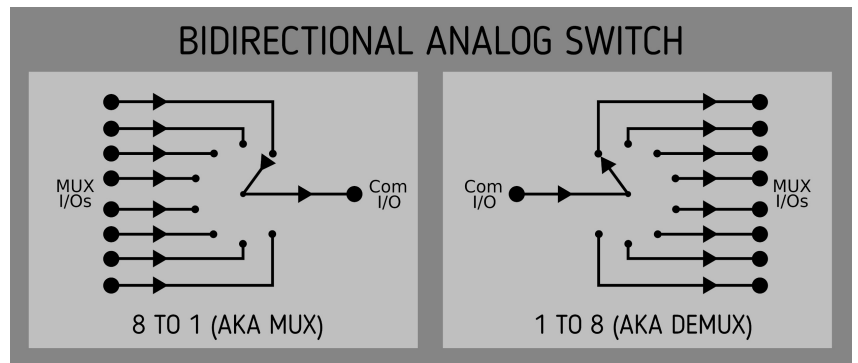

COMMON I/O

It is the main common Input/Output. **Through this jack you can either send a signal to the Mux I/Os or receive a signal from them (Depending on how the module it is connected).** It is also used as CV Out when nothing is connected to “All IN” or “Mux I/Os”. Use this output as CV out when using Muxlicer as step sequencer (see later).

ALL IN

Any signal plugged to ALL IN will go to all the “Mux I/Os” that don't have any other signal plugged on them.

All in, is there to send the same signal to any number of Mux I/Os.

Imagine you want to send a signal to the Steps 1,2,4,5,6 & 8. and a two more signals to 3 and 7 respectively. You just need 3 wires for this: plug the first one to All In and the other two to 3 and 7 Mux I/Os and you are done!

All In is normalled to a Voltage (selectable by the user), so **if nothing is plug to this IN, Muxlicer acts as normal step sequencer.** (Explained in Speed Div/Mult encoder / CV Range Section)

LEVEL FADERS

This faders attenuate the signals that goes from the “Mux I/Os” to the “common I/O” (or vice versa). When no signal is plugged to either “Mux I/Os” or “All IN” they act as CV Levels. This is because they Attenuate the default All IN voltage.

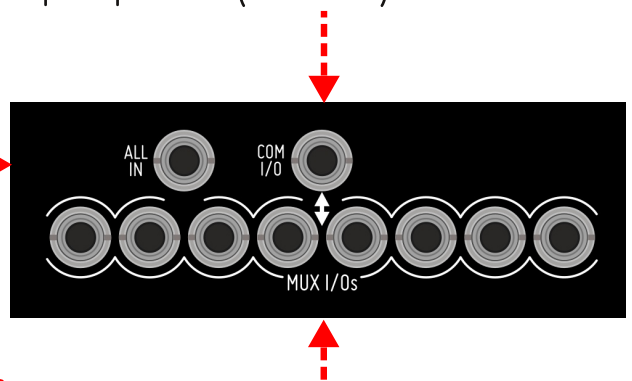

MUX I/Os

Mux I/Os are (together with Common I/O) the main connections of Muxlicer. Like common I/O, they are reversible. That means, depending on how the module is connected, **you can either send eight different signals to the “common I/O” or receive a signal from it at each of the 8 Mux I/Os.**

The eight Mux I/Os are normalled to “All In” jack, so any signal present at this input will go to all of them. (see ALL IN Section)

MISCELANEA | PATCH EXAMPLES

SLICING SIGNALS

With Muxlicer, you can slice any modular signal in the onboard analog switch circuit. Just plug a few signals into the Mux I/Os that you want, the COM I/O to your Out Module and press the play switch. Now you might listen a sequence with your signals sounding on their corresponding steps. If you plug a signal to All In input, it will be present in all the steps of the sequence except the ones that already have a signal. Finally, you can control the level of any signal with its corresponding level fader.

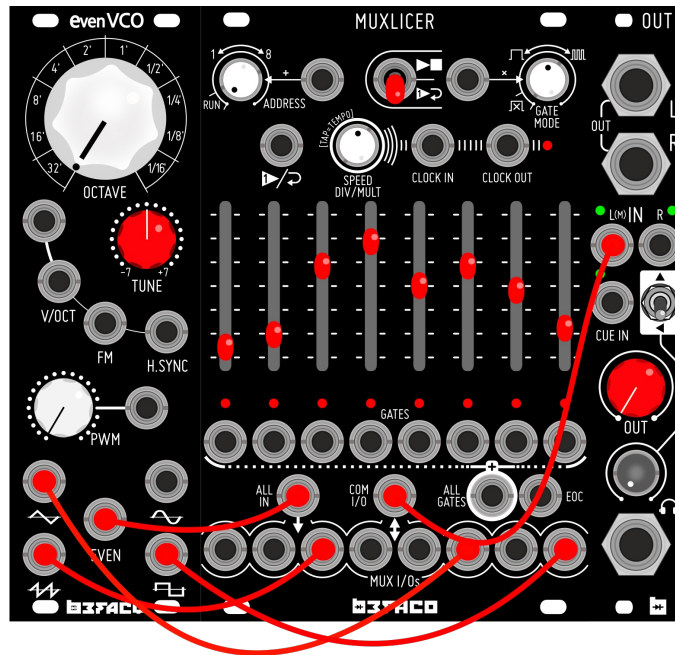

BASIC SEQUENCING

Without signals presents into the Analog Switch, the module works as a powerful 8 step Gate/CV sequencer with selectable CV range and gate retriggering. Just plug the COM I/O to the V/Oct input of your oscillator and the All Gate output to the gate/trig input of your voice envelope and you're ready to go. Set the note of each step with its corresponding level fader and adjust the range of the CV playing with the switch at the same time you press the encoder. Also you can control the retriggers of the gates via the Gate Mode pot and its associated CV input.

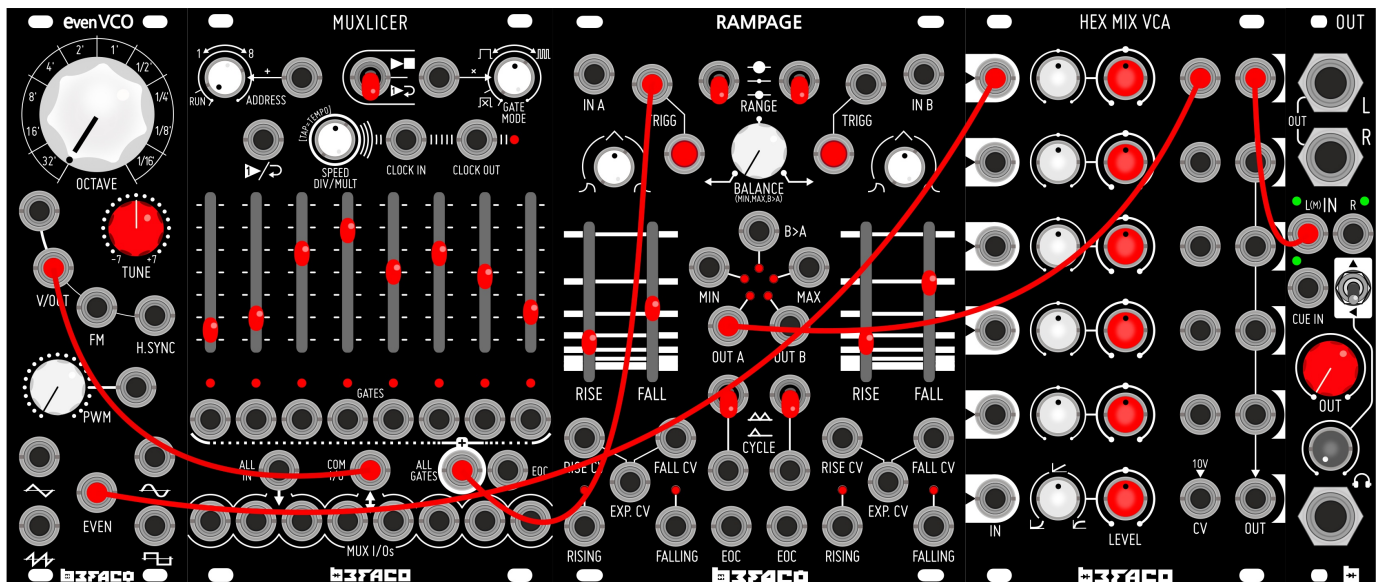

MISCELANEA | PATCH EXAMPLES

ADVANCED GATE SEQUENCER

One of the most cool features of Muxlicer is the possibility of being a complex gate sequencer with voltage controlled retriggering for each step. To do that, just plug the COM I/O to Gate Mode CV Input and the All Gates Output to the Trigger/Gate Input of your module. Put the CV range of Muxlicer to maximum and press the Play switch. Now you can adjust the amount of retriggerers in each step manually, with the sliders, or via CV, plugin CV signals to Mux I/Os. If you want to reduce the maximum number of retriggerers on the steps just play with the CV range till you like the result.

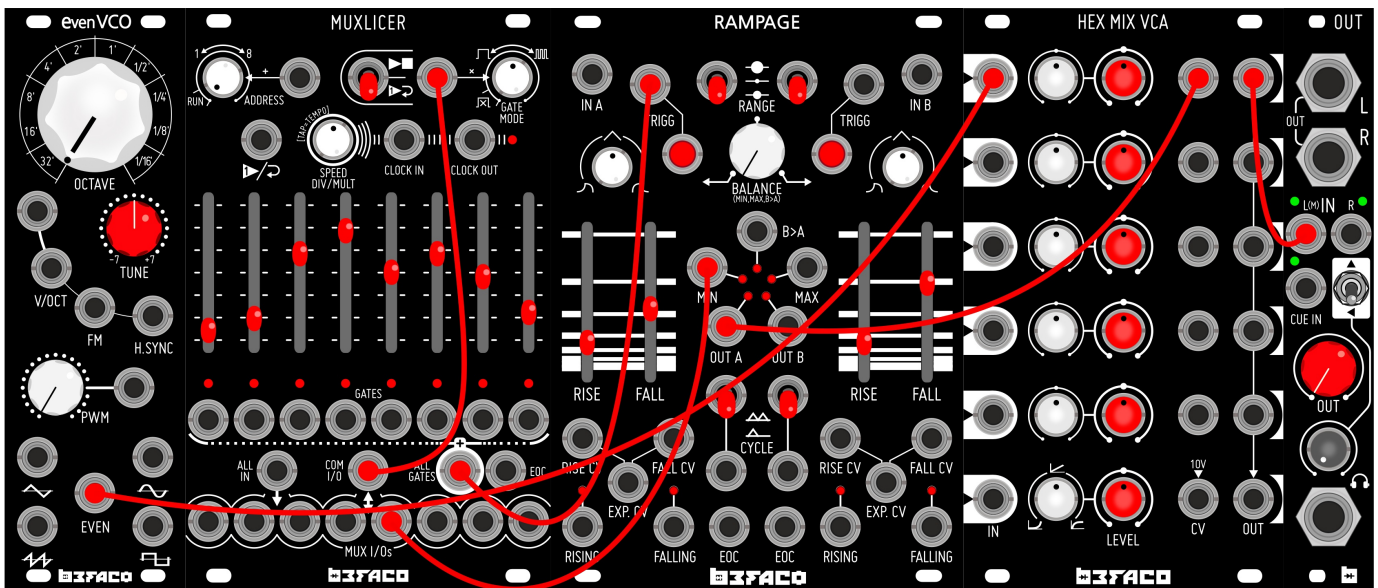

MISCELANEA | SPECS & CREDITS

- * **Size:** 16HP
- * **Depth:** 35mm
- * **+12v:** 50mA
- * **-12v:** 5mA



- * **Design:** Diego de León
- * **Firmware Coding:** Eloi Flores (Winter Modular)
- * **Special thanks to** Jonatan Bernabeu, Luis "Jicama" Sandoval, Sergi Margalef and all Befaco Team for their unvaluable help during the module development.