

***FISHMAN***<sup>®</sup>

---

**USER GUIDE  
SA330x**

[fishman.com](http://fishman.com)



Whenever this symbol appears, it alerts you to the presence of important operating and maintenance (servicing) instructions in the user's manual for this amplifier.





Wherever this symbol appears, it alerts you to the presence of uninsulated dangerous voltage inside the enclosure that may be sufficient to constitute a risk of shock.



## Important Safety Instructions

To ensure your personal safety and the safety of others, operate this apparatus only after reading these instructions and heeding the warnings listed below.

1. Read these instructions.
2. Keep these instructions.
3. Heed all warnings.
4. Follow all instructions.
5. Do not use this apparatus near water.
6. Clean only with a dry cloth.
7. Do not block the ventilation openings. Install in accordance with the manufacturer's instructions.
8. Do not install near any heat sources such as radiators, heat registers, stoves or other apparatus (including amplifiers) that produce heat.
9. Do not defeat the safety purpose of the polarized or grounding-type plug. A polarized plug has two blades with one wider than the other. A grounding-type plug has two blades and a third grounding prong. The wide blade or the third prong are provided for your safety. If the provided plug does not fit into your outlet, consult an electrician for replacement of the obsolete outlet.
10. Protect the power cord from being walked on or pinched, particularly at the plugs, convenience receptacles and the point where they exit from the apparatus.
11. Use only attachments/accessories specified by the manufacturer.
12.  Use only with a cart, stand, tripod, bracket or table specified by the manufacturer, or sold with the apparatus. When a cart is used, use caution when moving the cart/apparatus combination to avoid injury from tip-over.
13. Unplug this apparatus during lightning storms or when unused for long periods of time.
14. Refer all servicing to qualified service personnel. Servicing is required when the apparatus has been damaged in any way, such as a power-supply cord or plug is damaged, liquid has been spilled or objects have fallen into the apparatus, the apparatus has been exposed to rain or moisture, does not operate normally, or has been dropped.
15. Do not expose the apparatus to dripping or splashing liquids and do not place objects filled with liquids (such as a beverage container or a vase) on the apparatus.
16. Warning" To reduce the risk of fire or electric shock, do not expose this apparatus to moisture.
17.  The device is designed and evaluated under the condition of non-tropical climate; and, it can be only used in locations in non-tropical climate areas. Using the device in tropical climate areas would result in high safety risk.
18. Normal operating environmental temperature range: 0 °C [32 °F] to 40 °C [104 °F].
19.  The apparatus should be connected to mains outlet with a protective earthing connection.
20. No naked flame sources, such as lighted candles, should be placed on the apparatus.
21. Do not install this equipment in a confined or building-in space such as a book case or similar unit, and remain a well ventilation conditions at open site. The ventilation should not be impeded by covering the ventilation openings with items such as newspaper, table-cloths, curtains etc.



The mains plug/appliance coupler is used as disconnect device, the disconnect device shall remain readily operable.

Copyright © 2016 FISHMAN TRANSDUCERS, INC.

All rights reserved. No part of this document may be reproduced in any form without the written permission of FISHMAN TRANSDUCERS, INC.

## Hear This!

The SA330x amplifier is capable of cleanly reproducing the sound of your instrument at very high volume levels. Prolonged repeated exposure to high sound pressure levels (SPLs) without protection can cause permanent hearing loss. OSHA has set guidelines and specified permissible sound-exposure limits for those who work in high SPL environments.

### Permissible Noise Exposures

Duration per day, hours    Sound level dBA slow response

8	90
6	92
4	95
3	97
2	100
1 1/2	102
1	105
1/2	110
1/4 or less	115

To ensure against permanent hearing loss, wear hearing protection when you perform with amplification.



This symbol means the product must not be discarded as household waste, and should be delivered to an appropriate collection facility for recycling. For more information on disposal and recycling of this product, Contact your local municipality, disposal service, or the shop where you bought this product.

### FCC Compliance Notice

This equipment has been tested and found to comply with the limits for a Class B digital device, pursuant to Part 15 of the FCC Rules. These limits are designed to provide reasonable protection against harmful interference in a residential installation. This equipment generates, uses, and can radiate radio frequency energy and, if not installed and used in accordance with the instructions, may cause harmful interference to radio communications. However, there is no guarantee that interference will not occur in a particular installation. If this equipment does cause harmful interference to radio or television reception, which can be determined by turning the equipment off and on, the user is encouraged to try to correct the interference by one or more of the following measures:

- Reorient or relocate the receiving antenna.
- Increase the separation between the equipment and receiver.
- Connect the equipment into an outlet on a circuit different from that to which the receiver is connected.
- Consult the dealer or an experienced radio/TV technician for help.

NOTE: Fishman Transducers, Inc. is not responsible for unauthorized equipment modifications that could violate FCC rules, and/ or void product safety certifications.

**EU Declaration of Conformity CE:** Hereby, Fishman declares that this SA330x is in compliance with the essential requirements and other relevant provisions of Directive 2014/30/EU, 2014/35/EU. The Declaration of Conformity can be found at [www.fishman.com/support](http://www.fishman.com/support).

# Welcome

Thank you for choosing Fishman. We are proud to offer you professional-grade amplification products and accessories that will empower you to sound your very best.

Please read through this User Guide to familiarize yourself with the operation of your SA330x. Additional information and support can be found at [www.fishman.com](http://www.fishman.com)

## Setting the SA330x on its Stand

**When the SA330x is used as a portable PA system it is imperative that it be used with the included tripod speaker stand, and that it be placed directly on a level, solid, flat surface.**

Do not substitute the included Fishman tripod speaker stand with a non-Fishman part, or attempt to mount or suspend the SA330x in a permanent or temporary manner other than that as described in this guide or by Fishman.

1. To avoid accidentally being pushed over, or where it may be a trip hazard, locate the stand in a place that is free of obstructions.
2. Loosen the lower of the two large thumbscrews and spread the tripod legs. Follow the height warnings printed on the stand for safe operation (Figure 1). Setting the height outside this area is forbidden. Tighten the thumbscrew before placing the SA330x on the stand.
3. Remove the safety pin and loosen the upper large thumbscrew. Extend the top tube to the fourth hole or lower to match the “head level” of your audience. Replace the safety pin. Allow the tube to rest on this pin and then tighten the top thumbscrew (Figure 2).
4. Lift the SA330x using the handle on the back of the unit while supporting the weight with your other hand. A guide is molded into the underside of the SA330x and acts as an aid in positioning the SA330x onto the tripod. Once positioned, lower the SA330x onto the tripod until it rests firmly on the tube.

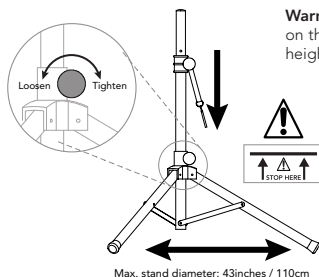

Figure 1.

4

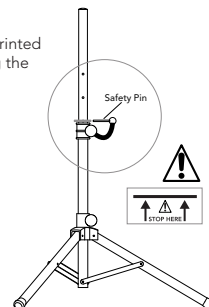

Figure 2.

## Cabling Precautions

When making your cable connections, always be sure to route the cables so that your audience, performers, or anyone else, will not trip over them or accidentally pull the SA330x over.

## Setting SA330x Controls

1. Locate the Power switch and switch it off, then connect the AC line cord into the back of the SA330x.
2. Plug the SA330x into an electrical outlet with the appropriate AC voltage.
3. Push in the Mute switch and turn on the Power switch.
4. Connect your instrument or other audio source to the Channel 1 input with an appropriate mic or instrument cable.
5. Play your instrument or other source material to the loudest level you anticipate during your presentation or performance and raise the Channel 1 Gain knob until the Clip LED flashes, then back off the Gain until no clipping occurs.
6. Set the controls as shown in the drawing.
7. Push the Mute switch (out) and slowly raise the Master Volume to the desired level.

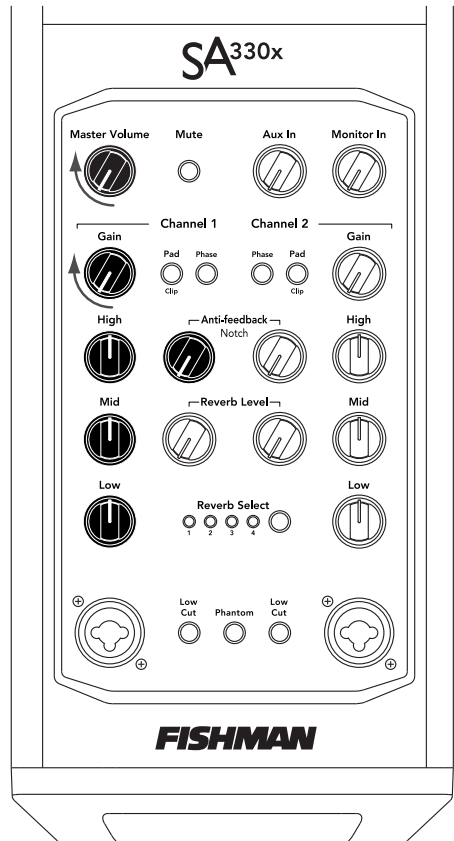

## Front Panel Controls

---

The following pages describe the functions of each control or jack on the front and rear panels of the SA330x. Refer to these numbered diagrams for each numbered control on the following pages.

- 1. Mute** – The Mute switch silences the signals from Channels 1 and 2 to the speakers and all the XLR outputs. It also mutes audio input from an audio device connected at the Accessory port. The mute does not affect the Aux inputs or Monitor input.
- 2. Master Volume** – Set the overall level of the SA330x here.  
Note: Controls 3 through 13 are identical for both channels.
- 3. 12dB Pad & Clip LED** – When you have a high output source and the Clip LED (located in the center of the Pad button) comes on at low Gain settings, push this switch to adjust your source level into a more useable range.
- 4. Gain** – Use the Gain knob to set the level of the signal.
- 5. Phase** – Use the Phase switch to improve low frequency response at low volumes or reduce microphone or instrument feedback at high volumes.
- 6. High** – Boost highs to add “air” and presence to your sound. With the knob set at 12 o’clock, the control is effectively out of the circuit.
- 7. Anti-Feedback** – If you encounter low-frequency feedback, sweep this notch filter control to isolate and eliminate the resonance. To learn more about acoustic feedback, see page 12.
- 8. Mid** – This control affects how well your source signal blends in or stands out in the mix. Slightly boosting the Middle control is useful for ensuring that vocals or speech are clear and intelligible. At loud volumes a midrange cut will achieve a more natural sound. With the knob set at 12 o’clock, the control is effectively out of the circuit.
- 9. Reverb Level** – Controls the amount of digital reverb in the channel.
- 10. Low** – Boost here to add weight to the sound. In general, boost bass at low volumes, and flatten it out (or cut) at higher levels. With the knob set at 12 o’clock, the control is effectively out of the circuit.

# SA330x

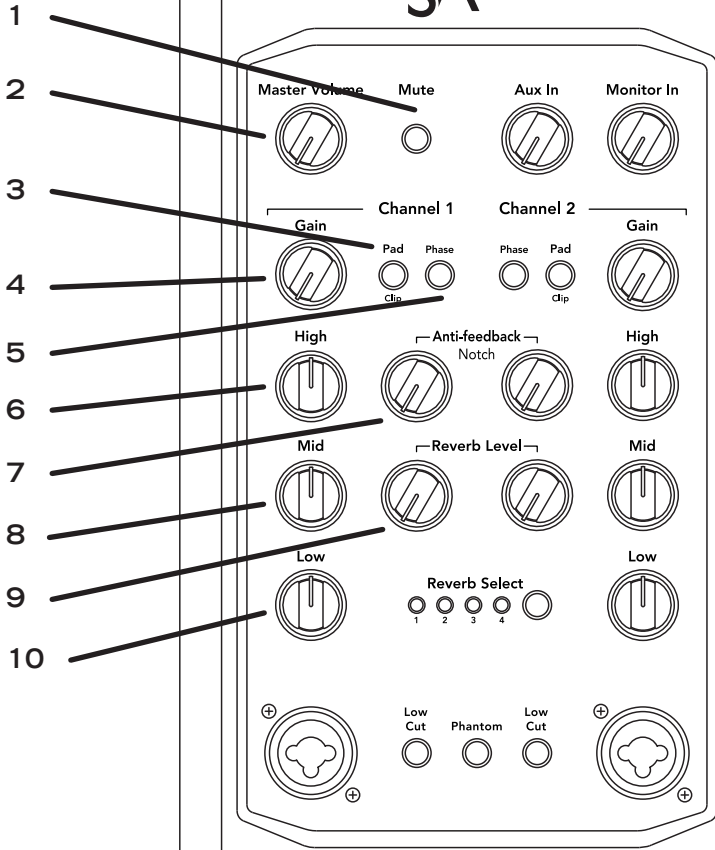

**FISHMAN**

## Front Panel Controls (cont.)

---

11. **Panel Lights** – LEDs built into the control panel housing help to improve readability of the controls in low-light situations.
12. **Input** – This combination 1/4" and XLR jack accepts all types of passive or active acoustic pickups, microphones, balanced or unbalanced outboard preamps and most other audio electronics.
13. **Low Cut** – Use this 80Hz filter to remove low frequency plosives or pops that may occur when using a microphone for speech or vocals.
14. **Aux In** – Use this to control the level of a device plugged into the Aux inputs. Note that the Aux channel is independent of the Mute switch.
15. **Monitor** – Use this to control the level of a second SA330x connected in the Monitor I/O setup as shown on page 13.
16. **Reverb (Select)** – Press the Reverb button to select among four preset reverb effects.
17. **Phantom Power** – Provides 48V to the XLR preamp in each channel for use with a condenser Microphone. The Phantom LED will light to indicate 48V is being supplied to the XLR jack.



SA330x

11

14

15

Master Volume Mute Aux In Monitor In



Gain Channel 1 Channel 2 Gain

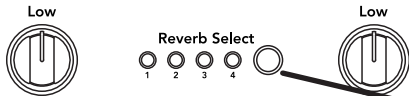
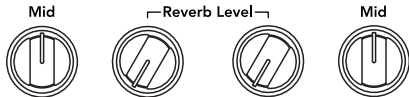
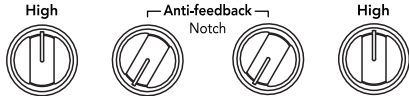

12

16

13

17

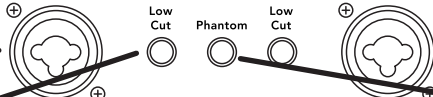

FISHMAN

## Rear Panel Controls

---

- 19. Aux Input** – Connect a line level stereo audio source such as a projector, CD or MP3 player to this input. Both inputs may be used at the same time. They are “stereo” (TRS) inputs, however the left and right signals are mixed to mono.
- 20. Tweeter Level** – Set the front panel controls flat (12 o’clock) and adjust the tweeter level to where it sounds best to you.
- 21. Channel 1 & 2 D.I. Out (Pre-EQ)** – Use this output when you want an unaffected, no-EQ, direct input signal to go to an additional mixer, recorder or other such device. This pre-EQ output is always ground-isolated to prevent ground loop hum.
- 22. Monitor In & Out** – The monitor feature on the SA330x allows two performers, each with an SA330x, to send their own mix to each other for simplified on-stage monitoring.  
  
Note: The Monitor In may also be used as additional audio input. The Monitor Out can also serve as additional line level mix output. This output is always ground isolated to prevent ground loop hum.
- 24. AC Power Switch & AC Power Inlet** – Connect the supplied, detachable AC power cable here and the other end to an AC mains power outlet appropriate for your region.
- 25. Mute Foot Switch** – Plug a two-button, latching-type foot switch into this jack to remotely mute the reverb or the channel mute. The channel mute function duplicates and overrides the front panel Mute switch.
- 26. Accessory Port** – Connect a compatible Fishman accessory here, such as an SA Expand, for one-cable power and audio expansion.
- 27. Sub Out** – The subwoofer output provides a dedicated, full-range audio out intended for use with a powered Fishman SA Sub. This output sends the proper level to the subwoofer and automatically activates a crossover inside the SA330x power amplifier to provide optimal sound and power at all output levels.
- 28. Mix D.I. (Post)** – Plug in here when you wish to send signals from both Input channels, the Aux input and an Accessory port device to a mixing console. This post-EQ output is always ground isolated to prevent ground loop hum.

**FISHMAN**  
 Designed and Engineered in the U.S.A.  
 by Fishman Transducers, Inc.  
 Assembled in China

**SA330x**

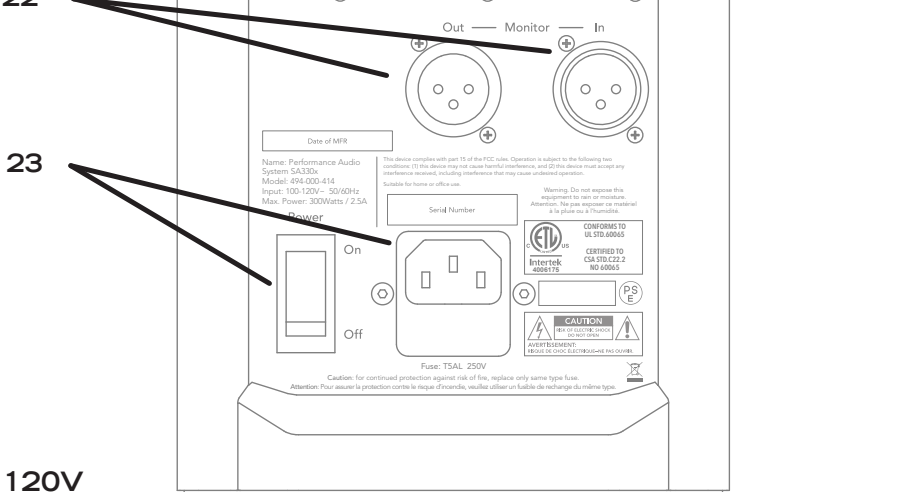
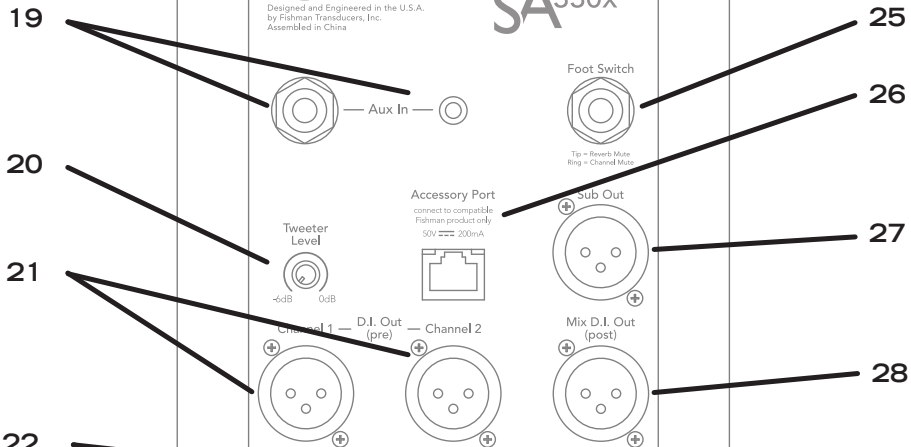

**120V**

**240V**

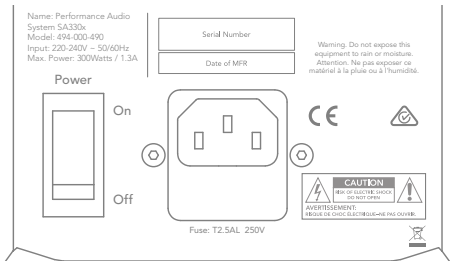

## About Acoustic Feedback

---

There are two features to help control acoustic feedback when using the SA330x with a microphone or acoustic instrument – the Phase switch and the Anti-Feedback notch control.

Feedback usually occurs when the natural resonances of a microphone or an instrument react with amplified sound. The louder these sounds are amplified, the more they can interact. Feedback occurs when a sound resonates in sync with the amplified sound, reinforcing and building to a sustained howl.

**Phase Switch** – The Phase switch flips the polarity of the input signal from positive to negative, changing its relationship to the sound coming from the amplifier. One phase setting usually provides better resistance to feedback than the other and will vary depending on the input source or instrument and the playing environment. Another approach to determining optimal phase is choosing the switch position that sounds or feels most natural. In certain environments the Phase switch may not have an audible impact.

The Phase switch also affects the signal polarity to the balanced D.I. and Monitor outputs, synchronizing the amplifier with other sound systems in use.

**Anti-Feedback** - The Anti-Feedback control is a variable frequency notch filter designed to subdue a resonant peak of a sound source that might be prone to feedback. Turning this knob adjusts the center frequency of the filter, ranging from subsonic (off) to 330Hz at full clockwise. To adjust this feature, try to induce feedback and then turn the control until the intensity is diminished.

## Setting Phase and Anti-Feedback

---

1. Start with the Anti-Feedback control turned down completely.
2. Turn up the Volume and or Gain on the SA330x until feedback begins.
3. Flip between the two Phase positions. Each position will produce a different dominant feedback frequency. Listen to the frequencies and select the Phase position which allows the higher note to feedback while subduing the lower.
4. Adjust the Anti-Feedback knob clockwise until it subdues the frequency of the higher feedback note.

Since optimal tone is a matter of taste, one can also experiment with reversing the order, using the Phase switch to control the upper feedback note and the Anti-Feedback notch for the lower.

## Monitor I/O Connections

The monitor feature on the SA330x allows two performers, each with an SA330x, to “cross-feed” their EQ’d and mixed outputs to each other. This allows each player to turn up the other player’s mix and hear them through their own SA330x.

Connect two SA330xs as shown, and then turn up the Monitor control to mix-in the other performer’s SA330x.

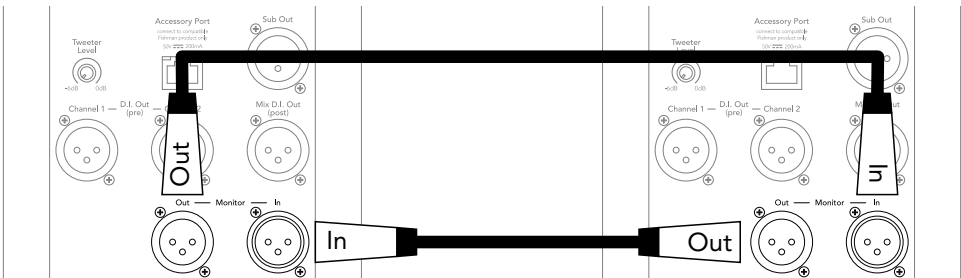

## Accessory Port Connections

SA330x's Accessory port provides system power and audio return paths for a compatible Fishman device, such as an SA Expand. After connecting the accessory, confirm that the green LED in the RJ-45 connector is lit. Wait 10 seconds for the device to become operational before disconnecting and reconnecting.

In order to provide the safest operation of your SA330x, the Accessory port features fault-handling during power-on and while connecting & disconnecting compatible accessory devices. For this reason, the RJ-45 connector has LEDs built-in to indicate the following:

**Normal operation** – When a compatible accessory is connected, a **green** LED will light to reflect normal operation.

**Fault condition** – While disconnecting and reconnecting a compatible device quickly, a fault condition may occur and will be indicated by a **yellow** LED. To restore normal operation, turn the SA330x power off for at least 10 seconds, then **ON** again, and power to the device will be restored.

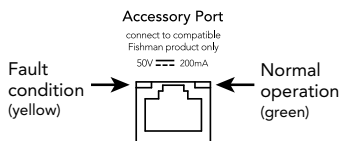

# Block Diagram

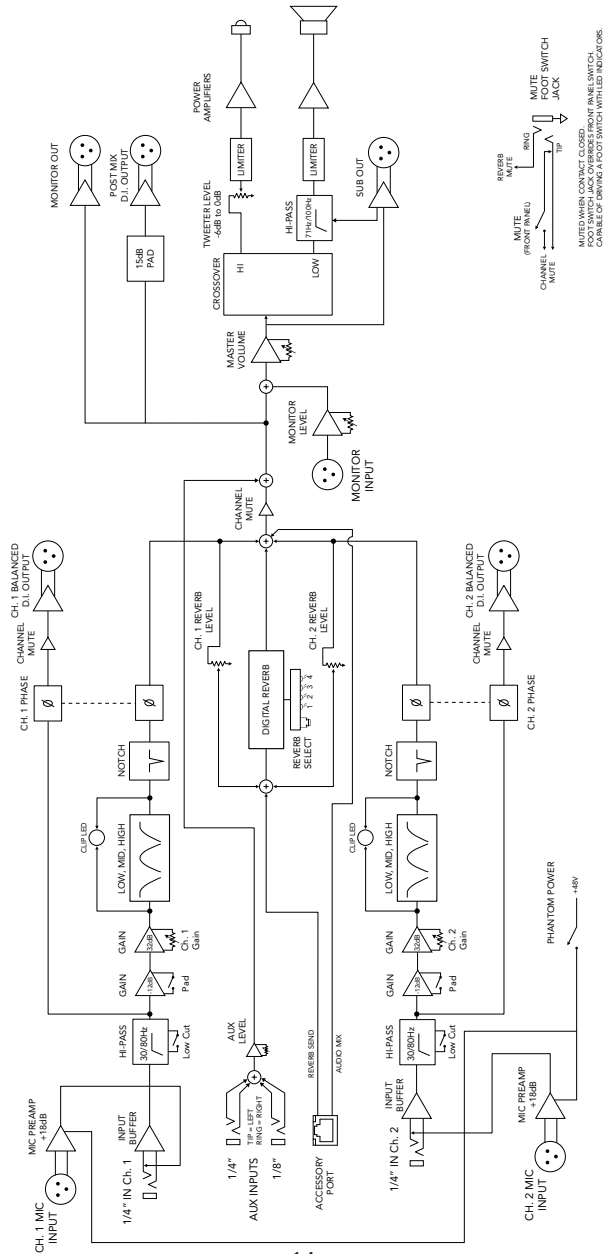

## Technical Specifications

---

### Input Impedance:

1/4" Input	5M Ohm
XLR Input	3k Ohm Balanced
Aux Input (stereo)	10k Ohm

### Tone Controls and Anti-Feedback:

Low	±12.5dB @ 50Hz (resonant)
Mid	±10.5dB @ 750Hz (resonant)
High	±12.5dB @ 10kHz (shelving)
Anti Feedback range	-14dB @ 15Hz – 330Hz (Hi-Q resonant notch)

### Channel 1 & 2 D.I. Output:

Output Impedance	600 Ohm balanced Phantom power tolerant, ground isolated
------------------	---

### Mix D.I. Output:

Output Impedance	600 Ohm balanced Phantom power tolerant, ground isolated
------------------	---

### Sub Output:

Output Impedance	600 Ohm balanced Phantom power tolerant, ground isolated
------------------	---

### Speaker System:

Woofer	Six 4" patented dual-gap with neodymium magnet
Tweeter	1" soft dome, neodymium magnet
Tweeter Level	Up to 6dB cut @ 10kHz
Crossover	Bi-amplified with active crossover 100Hz High-pass filter when Sub Out connected

### Amplifier:

Woofers	280W rms; 484W peak
Tweeter	50W rms; 100W peak
Frequency Response	71Hz – 20kHz

**Power Consumption:** 300W max

### Physical:

Dimensions	41.4" H x 5.5" W x 6.7" D 105.2cm H x 14.0cm W x 17.0cm D
Weight	20lbs (9.1 kg) without stand and carry bag

***FISHMAN***<sup>®</sup>

fishman.com