

---

# APOLLO LIGHT

---

The Apollo Light is an entry level lamp manufactured to a professional standard. This rugged light is constructed entirely of metal and runs off a 24V supply.



**RAT**stands

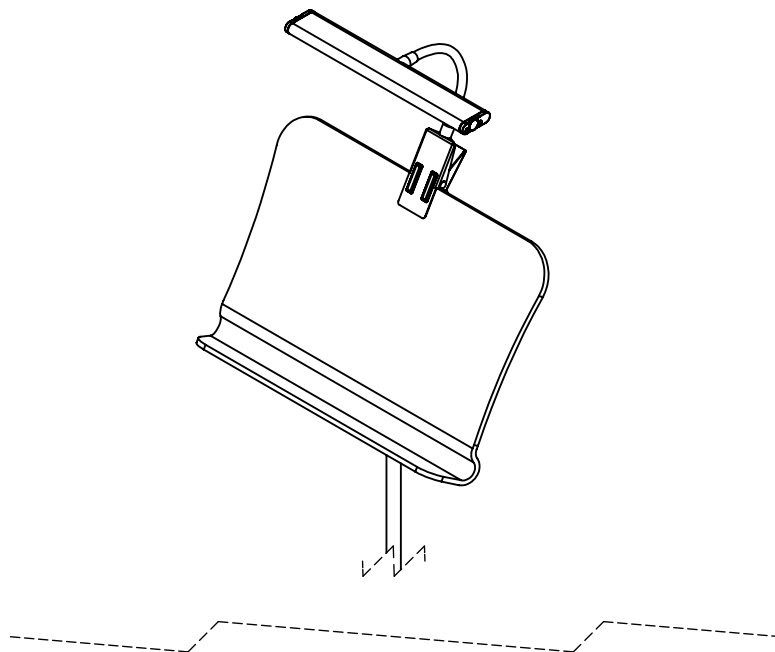
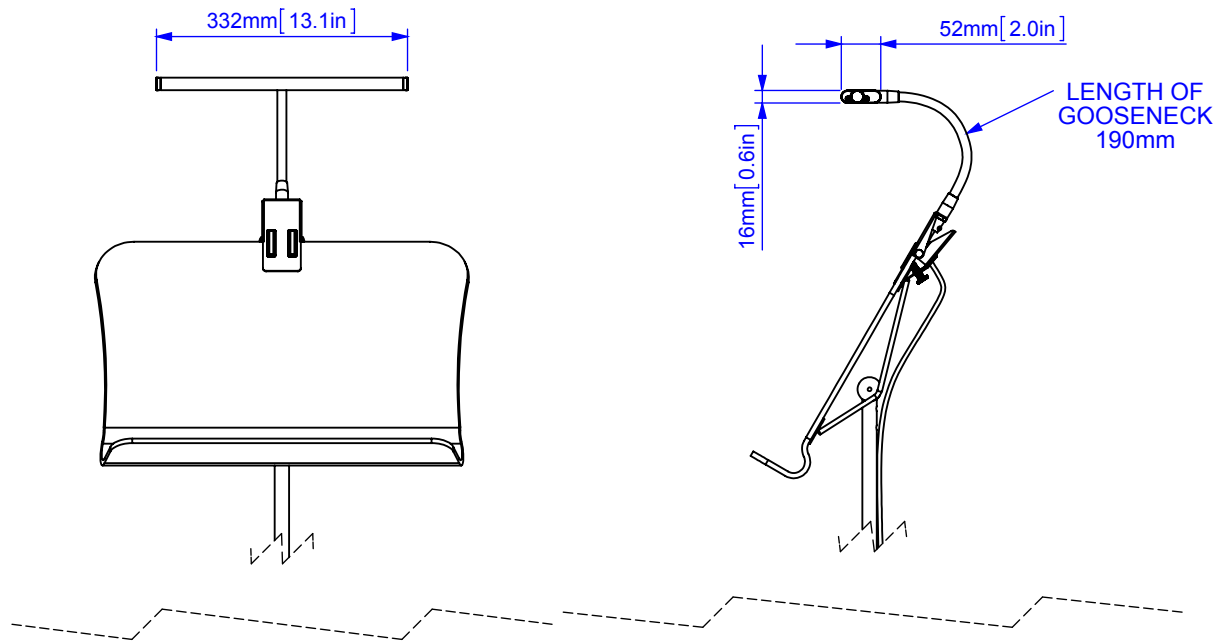

## Specifier's description

Universal music stand light with powerful spring clip. Slim aluminium housing, 16mm thick, containing eighteen LEDs with a colour temperature of 3000K.

Low voltage light which can be powered by battery or mains power in conjunction with the correct PSU.

Construction	
Structural parts	Steel
Lamp housing	Extruded aluminium
Cable type	Straight cable with PVC outer sheath
Electrical connector type	DC plug

Dimensions	
Profile of lamp as seen by user: thickness	16mm [0.6in]
Profile of lamp as seen by user: width	330mm [13.0in]
Rotation of lamp housing	As permitted by the gooseneck
Cable length	2500mm [98.5in]
Weight	0.6kg [1.3lb]

Optical characteristics	
Colour temperature	3000K
CRI	80 min
Life of LEDs to 70% of initial output (L70)	50,000hrs
Luminous flux from LEDs	300 lm

Electrical characteristics	
SELV (Safety extra low voltage)	YES
Operating voltage	24V
Electrical power consumption	4.3W
Circuit luminous efficacy	70 lm/W

General	
Commercial use warranty	2 years
Applicable standards	EN55022 EN60598 EN60529
IP rating	IP32
RATstands part number	73Q06